



USE AND MAINTENANCE MANUAL

CONTROL AND MANAGEMENT KIT FOR METERING PUMPS

PRO

PRO UL



YEAR 2021.06



ATTENTION:

Industrial machinery not intended for use by non-professional operators. These instructions are intended for qualified personnel.

Doc. No. UT-5601	Rev. 4	Lang. EN	1 st Issue 24/06/2020
Prepared by A.A.	Checked by C.V.C.	Replaced on	

REVISION INDEX

Chapters	Rev	Date	Rev	Date	Rev	Date	Rev	Date	Rev	Date
Index	0	20/06/2018	1	05/10/2018	2	07/02/2019	3	24/06/2020	4	01/03/2021
0	0	20/06/2018			2	07/02/2019				
1	0	20/06/2018			2	07/02/2019	3	24/06/2020		
2	0	20/06/2018					3	24/06/2020		
3	0	20/06/2018			2	07/02/2019	3	24/06/2020		
4	0	20/06/2018	1	05/10/2018			3	24/06/2020	4	01/03/2021
5	0	20/06/2018	1	05/10/2018			3	24/06/2020		
6	0	20/06/2018					3	24/06/2020	4	01/03/2021
7	0	20/06/2018					3	24/06/2020		
8	0	20/06/2018					3	24/06/2020		

Date	24/06/2020										
Signature											

TABLE OF CONTENTS

REVISION INDEX	1
TABLE OF CONTENTS	2
0 INTRODUCTION	3
1 SCOPE OF THE USE AND MAINTENANCE MANUAL	3
2 HOW TO READ THIS USER MANUAL	3
1 GENERAL INFORMATION	4
1 MANUFACTURER'S IDENTIFICATION DATA	4
2 CE MARKING	4
3 UL MARKING	5
4 DECLARATIONS	6
5 UL CERTIFICATION	7
6 TECHNICAL SUPPORT - INFORMATION	8
2 SAFETY	8
1 GENERAL SAFETY WARNINGS	8
2 USE RESTRICTIONS	8
3 ELECTROMAGNETIC COMPATIBILITY	8
4 SAFETY	9
5 SAFETY PICTOGRAMS	9
3 INSTALLATION	10
1 TRANSPORT AND HANDLING	10
2 STORAGE CONDITIONS	10
3 POSITIONING	11
4 ADJUSTMENTS	11
5 ASSEMBLY	12
6 ELECTRICAL CONNECTIONS	13
4 PRODUCT DESCRIPTION	16
1 OPERATING PRINCIPLE	16
2 MAIN COMPONENTS AND DIMENSIONS	17
3 ENVIRONMENTAL CONDITIONS	19
4 TECHNICAL DATA	20
5 USE AND SOFTWARE	21
1 INTERFACE	21
2 ICONS	21
3 MENU	22
6 MAINTENANCE	39
1 ROUTINE MAINTENANCE	39
2 TROUBLESHOOTING	40
7 ACCESSORIES AND SPARE PARTS	41
1 ASSISTANCE	41
2 SPARE PARTS	41
8 ADDITIONAL INSTRUCTIONS	42
1 DECOMMISSIONING AND DISASSEMBLY	42

0 INTRODUCTION

1 SCOPE OF THE USE AND MAINTENANCE MANUAL

This manual provides the user with general guidelines to use the product safely.

This User Manual is an integral part of the product and provides the following information about the product:

- technical specifications;
- a description of its operation and limits;
- instructions on how to use it under safe conditions;
- instructions on how to perform maintenance and repairs correctly and safely;
- technical support;
- instructions on waste disposal.

2 HOW TO READ THIS USER MANUAL

This manual is divided into chapters. Each one of them provides specific information.

NUMBERING OF THE FIGURES

Each figure is numbered progressively.

NUMBERING OF THE TABLES

Each table is numbered progressively.

The progressive number starts from 1 at every new paragraph.

ABBREVIATIONS

- Cap. = Chapter
- Par. = Paragraph
- Sec. = Section
- Page = Page
- Fig. = Figure
- Tab. = Table

1 GENERAL INFORMATION

1 MANUFACTURER'S IDENTIFICATION DATA

MANUFACTURER	OBL S.R.L.
REGISTERED HEADQUARTERS AND ADMINISTRATIVE OFFICE	Via Kennedy 12 - 20090 Segrate (MILAN) ITALY
TELEPHONE NUMBER	0039 02 26 91 91
E-MAIL	Obl.info@idexcorp.com

2 CE MARKING

Every KIT-PRO product is identified with a CE label indicating its reference data, which are printed indelibly.

The CE marking label contains the following information:

- 1:** OBL METERING PUMPS
- 2:** Via Kennedy n°12 - Segrate - MILANO
- 3:** +39 02 26 9191 - obl.info@idexcorp.com
- 4:** MODEL KIT-PRO
- 5:** 230 V
- 6:** 50 Hz
- 7:** MAX CURRENT 4.2 A
- 8:** MAX POWER 1500 VA
- 9:** MAX MOTOR POWER 750 W
- 10:** ENCLOSURE IP65
- 11:** SERIAL No. 2018P4831
- 12:** 06/2018

1=Product model	6=Protection rating
2=Power supply voltage	7=Serial number
3=Maximum current consumption	8=Month and year of manufacture
4=Power supply frequency	9=Max power of the motor
5=Maximum power consumption	

3 UL MARKING

Every KIT-PRO UL product is identified with a UL label indicating its reference data, which are printed indelibly.

OBL <small>METERING PUMPS</small> OBL S.r.l. - Via Kennedy n°12 - Segrate - MILANO +39 02 26 9191 - obl.info@idexcorp.com		 EAC CE	
MODEL		KIT-PRO UL	
INPUT	PHASE No VOLTAGE CURRENT POWER FREQUENCY	2 + PE 110/230 Vac 4.2 A 1.5 kVA 50/60 Hz	
OUTPUT	PHASE No VOLTAGE CURRENT PWM	3 + PE 110/230 Vac 3 A 3,3 A ON/1,6 A OFF (0.2s ON 50%) 0-15 kHz	
TYPE	4X outdoor	YEAR	2018.02
Suitable for use on a circuit capable of delivering no more than 5000 Arms Symmetrical Amperes, 230 Vac max when protected by CC class fuses The drive does not provide motor Overload protection. External or remote Motor Overload protection shall be provided in the end-use application Motor over-temperature sensing is not provided by the drive and it shall be provided in the end-use application			

1=Product model	4=NEMA type
2=Product input data	5=Manufacturing year and month
3=Product output data	6=Warnings

4 DECLARATIONS



EU DECLARATION OF CONFORMITY (UT5604-0) (ANNEX IV, DIR. 2014/35/EU) THE MANUFACTURER

COMPANY NAME	OBL SRL
ADDRESS	VIA KENNEDY 12, 20090 Segrate – MILAN - Italy

DECLARES THAT THE PRODUCT

NAME	MODEL
KIT PRO	KIT PRO

COMPLIES WITH THE FOLLOWING EUROPEAN DIRECTIVES

DIRECTIVE 2014/35/EU of the European Parliament and Council, dated 26 February 2014, on the harmonisation of the laws of the Member States relating to the making available on the market of electrical equipment designed for use within certain voltage limits

DIRECTIVE 2014/30/EU of the European Parliament and Council, dated 26 February 2014, on the harmonisation of the laws of the Member States relating to electromagnetic compatibility (recast)



AND THAT THE FOLLOWING STANDARDS HAVE BEEN APPLIED (PARTS/ARTICLES OF HARMONISED STANDARDS)

EN 61800-5-1	Adjustable speed power drive systems - Part 5-1: Safety provisions - Electric, thermal, and energy safety
--------------	---

DATE AND PLACE

Segrate, 26/06/18

SIGNATURE

CERTIFICATE OF COMPLIANCE

Certificate Number 20181226-E504591
Report Reference E504591-20181220
Issue Date 2018-DECEMBER-26

Issued to: OBL srl
Via Kennedy 12
20090 Segrate MI ITALY

This certificate confirms that representative samples of POWER CONVERSION EQUIPMENT Enclosed type 4X – Power Conversion Equipment – Motor Drive Model KIT-PRO.

Have been investigated by UL in accordance with the Standard(s) indicated on this Certificate.

Standard(s) for Safety: UL 61800-5-1, Adjustable Speed Electrical Power Drive Systems - Part 5-1: Safety Requirements - Electrical, Thermal and Energy and CSA C22.2 No. 274-17, Adjustable Speed Drives

Additional Information: See the UL Online Certifications Directory at <https://iq.ulprospector.com> for additional information.

This *Certificate of Compliance* does not provide authorization to apply the UL Mark.

Only those products bearing the UL Mark should be considered as being UL Certified and **covered under UL's Follow-Up Services**.

Look for the UL Certification Mark on the product.



Bruce Malenki, Director North American Certification Program
UL LLC

Any information and documentation involving UL Mark services are provided on behalf of UL LLC (UL) or any authorized licensee of UL. For questions, please contact a local UL Customer Service Representative at info@ul.com or <http://www.ul.com/certification>.



6 TECHNICAL SUPPORT - INFORMATION

This product is guaranteed as stated in the general terms and conditions of sale. Should malfunctions or failures (included within the cases covered by the warranty) be detected during the warranty period, the Manufacturer will repair or replace the defective parts, prior to verification.SAFETY

2 SAFETY

1 GENERAL SAFETY WARNINGS

The Manufacturer has designed this product to make it as SAFE as possible.

Every OBL KIT PRO is a reliable, quality product, which undergoes careful end inspection to ensure proper operation and ascertain compliance with specified performance.

The Manufacturer of the machine must install the product and comply with all the regulations and safety standards in force in the country of installation.

Attention! When using mains-powered equipment, always follow basic safety precautions, including the following, to reduce damage to people and property:

 Carefully read the instructions in this manual before installing/using the device.

 Keep these instructions for future use.

2 USE RESTRICTIONS

The PRO KIT can be installed only and exclusively on the following pump models:

1. OBL's metering pumps of the Black Line series (M diaphragm version)
2. OBL's metering pumps of the Black Line series (R piston version)
3. OBL's metering pumps of the Black Line series (XRN version)

3 ELECTROMAGNETIC COMPATIBILITY

The user is the only responsible for solving problems related to electromagnetic compatibility once the finished product is completely produced. In some cases, the equipment needs to be earthed correctly, while in others a screen may be required. The manufacturer of the KIT PRO is available to help the user solve problems related to electromagnetic compatibility upon request.

4 SAFETY

- Carefully read this use and maintenance manual before starting, using, performing maintenance, or any other operation on the equipment.
- Strictly comply with the warnings contained in the manual, whether they indicate danger or caution.
- The operator must meet all the requirements for using this type of machine.
- Always wear personal protective equipment in compliance with the occupational safety regulations in force.
- Before proceeding with the installation, make sure that the area does not feature any dangerous condition. Make sure no foreign bodies have been left inside or on the machine.
- Start the machine start-up sequence following the instructions.
- Do not enter the machine's operating area while the machine is running.
- Do not introduce your hands or anything else near or inside the equipment live parts.
- Do not work in dark conditions. Use all the lights available, making sure they are efficient.
- Do not use the machine when under the influence of medicines or alcohol, as they may impact your capacity of moving and thinking.
- Stay concentrated and use caution before carrying out any operation.
- Always keep the work area clean.
- Warn the maintenance managers about any malfunction of parts or systems on board the machine.
- Do not wear loose clothing, but always accident-prevention clothing.

NOTE (for UL version): Integral solid state short circuit protection does not provide branch circuit protection. Branch circuit protection must be provided in accordance with the National Electrical Code and any additional local codes.

CSA: INTEGRAL SOLID STATE SHORT CIRCUIT PROTECTION DOES NOT PROVIDE BRANCH CIRCUIT PROTECTION. BRANCH CIRCUIT PROTECTION MUST BE PROVIDED IN ACCORDANCE WITH THE CANADIAN ELECTRICAL CODE, PART I.

5 SAFETY PICTOGRAMS

The device is installed on OBL metering pumps. Pay attention to the safety pictograms on the pumps.

3 INSTALLATION

1 TRANSPORT AND HANDLING

The KIT-PRO / KIT-PRO UL can be handled manually as it weighs only 5 kg. Always transport the product inside its original packaging.

2 STORAGE CONDITIONS

If not used immediately, the KIT-PRO/KIT-PRO UL should be stored with suitable covers in a temperate, dry, clean, vibration-free and weatherproof environment. Protect from soil moisture by placing the unit on shelves or wooden pallets. If the temperature is below 0°C, ensure that it does not go lower than -10°C. If not specifically highlighted on the package, do not stack packaging, to prevent damage to the KIT-PRO and to avoid tipping over or falling that can create accidents. Ensure that access of unauthorized persons is not allowed in the storage location and that the floor or shelf can support the weight of the machinery or equipment stored. Take additional safety measures in the case of storage in extreme conditions, i.e. in sub-tropical or desert climates.



Report special storage conditions in advance in order to provide for adequate packaging.



Check the dimensions and overall gross weight of the package before handling or lifting it.

3 POSITIONING

The Black Line 2.0 M and R pumps can be installed on a KIT-PRO, as shown in Figure 1.

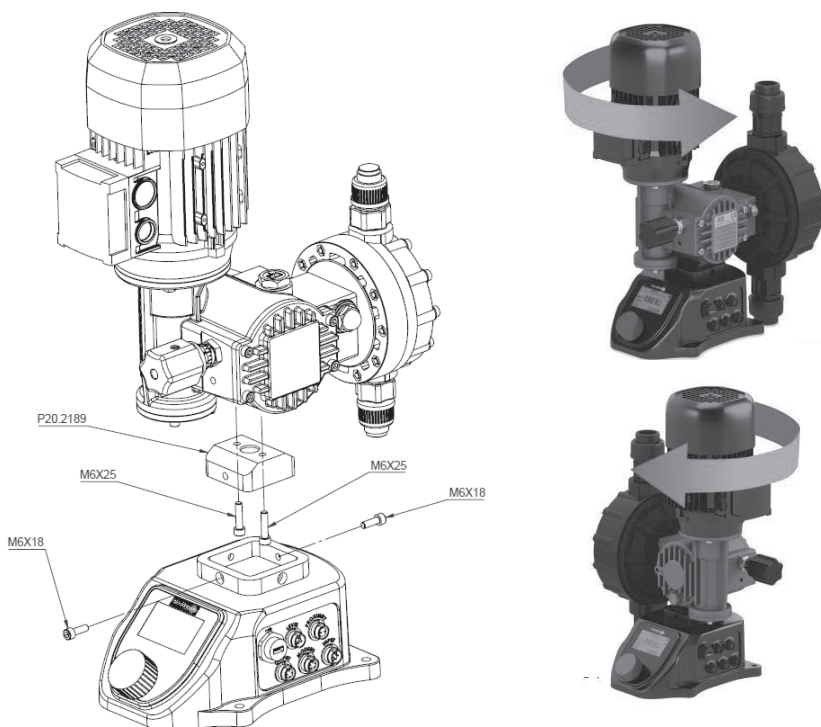

Figure 1 Installation of the KIT

Moreover, the orientation of KIT-PRO / KIT-PRO UL can be changed from 0 to 90° compared to the pump. To carry out this operation, you just have to:

1. unscrew the 2 screws (M6x18)
2. rotate the pump
3. tighten the 2 screws (M6x18)

4 ADJUSTMENTS

See chapter 5 "USE AND SOFTWARE".

5 ASSEMBLY

The KIT PRO /KIT PRO UL can be supplied in two versions:

- Assembled on an OBL metering pump (Black Line series)
- The assembly kit can be assembled and installed on an OBL Black Line 2.0 metering pump (manufactured from May 2017 onwards)

The KIT PRO must be assembled on pumps not installed in a system. **Contact an OBL distributor in the event the OBL pump on which the KIT PRO is to be installed is already operating in a system.**

The KIT PRO is suitable for all OBL metering pumps of the Black Line series with a standard motor (three-phase power supply 380V/230V/110V 50/60 Hz). Contact an OBL distributor in the event motors with different characteristics are installed.

Follow the instructions below to assemble the KIT PRO on OBL's Black Line metering pumps:

1. Make sure the motor is not powered
2. Make sure that the OBL metering pump on which the KIT PRO is to be installed is not running.
3. Disassemble the base of the Black Line pump (pos. 117 in the BL2.0 M and R section drawings)
4. Mount connection P20.2189 (Figure 1) using the M6x25 screws.
5. Fasten the KIT PRO to the connection (Figure 1) using the provided M6x18 screws.
6. Disconnect any connection to the electric motor terminal box of the Black Line metering pump.
7. Connect the KIT PRO's output cable to the terminal box of the Black Line pump's motor, making sure that the connection is **delta (230 V)** like the picture on the side. Refer to the use and maintenance manual of the Black Line metering pump, chapter 2 paragraph 6, and chapter 8. In the following table please find the information regarding colour conductors associated to the interconnection of the motor and power supply. The device shall be connected using this information.

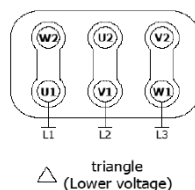

Table 1 Motor and power supply interconnections

CONNECTOR CABLE GLAND	CONDUCTOR FUNCTION	KIT-PRO COLOUR	CONDUCTOR COLOUR	KIT-PRO CONDUCTOR COLOUR	UL
MOTOR	U	Blue or Grey		Red	
	V	Brown		White	
	W	Black		Black	
	GROUND	Yellow/Green		Green	
POWER	L	Black or brown		Black	
	N	Blue		White	
	GROUND	Yellow/Green		Green	

8. KIT-PRO must be fixed to a stable support by tightening the M8 screws into the $\varnothing 8.5$ holes on the body (Figure 2).

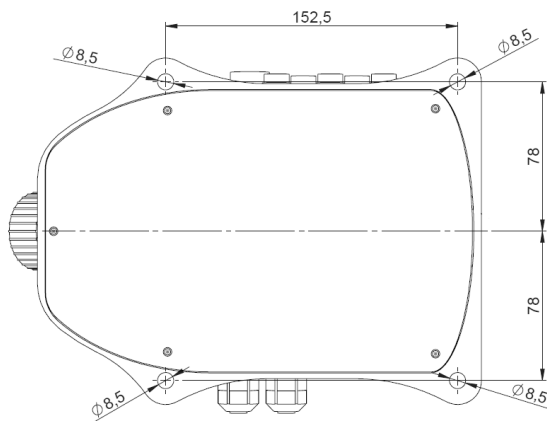

Figure 2 Fastening holes

9. **Before making electrical connections, make sure that the power mains voltage matches the information contained on the KIT PRO /KIT PRO UL data plate.**

6 ELECTRICAL CONNECTIONS

6.1 Power supply connection

The cable glands should be tightened so that seal rings keep the necessary pressure:

- to prevent transmission of mechanical stress on the motor terminals
- to ensure mechanical protection (IP degree) of the terminal box

 **NOTE:** Always make the earth connection using the appropriate earth wire on the main power cable.

NOTE: In the event of power outage or disconnection, let the screen switch off before reconnecting the power supply.

NOTE: For KIT-PRO UL cable glands should be tightened considering the following torques:

1. Panel I/O Cable Gland = in-lbs (N-m)= 79.6 (9)
2. Power Cable gland: in-lbs (N-m)= 97 (11)

6.2 Signal connection

The KIT PRO has different signal connections, whose name are shown on the enclosure.

The KIT includes the relative connectors, which are provided with a 1-meter cable. The cables supplied feature 4 conductors featuring different colours. The function of the input cables changes depending on the hardware version. Please check the hardware operating on the controller in the menu settings→firmware info→version. The version of the hardware can be 0.1 or 0.2 (from the end of 2020). Table below **Errore. L'origine riferimento non è stata trovata.** shows the connectors needed.

Table 2 Connectors

CONNECTOR	PIN FUNCTION	KIT-PRO CONDUCTOR COLOUR	KIT-PRO CONDUCTOR COLOUR	UL
INPUT (HW 0.1)	Remote Start/Stop (contact)	Yellow	Red	
	Pulses (contact)	Green	Green	
	Ground (-) (common for all pins of input connector)	Brown	White	
	4-20 mA/0-10V analogue (+) (passive signal: power supply needed)	White	Black	
INPUT (HW 0.2)	Remote Start/Stop	Yellow	Red	
	Remote Ground	Green	Green	
	4-20 mA/0-10V/pulse (-) (passive signal: power supply needed)	Brown	White	
	4-20 mA/0-10V/pulse (+) (passive signal: power supply needed)	White	Black	
MODBUS	A	Yellow	Red	
	B	Green	Green	
	Ground (-)	Brown	White	
OUTPUT (HW 0.1)	4-20 mA analog (+) (passive signal: power supply needed)	Yellow	Red	
	4-20 mA analog (-) (passive signal: power supply needed)	Brown	White	
	Relays	Green	Green	
	Relays	White	Black	
OUTPUT (HW 0.2)	4-20 mA analog (+) (active signal: no power supply needed)	Yellow	Red	
	4-20 mA analog (-) (active signal: no power supply needed)	Brown	White	
	Relays	Green	Green	
	Relays	White	Black	

LEVEL	Start	Green	Red
	Stop	Yellow	Green
	Ground (common for all pins of level connector)	Brown	White
USB 2.0 HOST	VBUS	Suitable for the connection of a USB flash drive	Red
	D-		Green
	D+		White
	Ground		Black
Proximity	0 V	Suitable for the connection of the supplied proximity sensor.	Red
	Proximity		Green

6.3 Connecting the stroke counter sensor (proximity)

The stroke counter sensor Figure 8 is provided with the KIT PRO.

To install it, you just have to:

1. Loosen the oil cap (pos. 119 of the section drawing)
2. Tighten the proximity sensor in the oil cap housing
3. Connect the proximity sensor to the electronics using the appropriate connector

NOTE: The proximity sensor is supplied with a spacer. Use the spacer considering the recommendations hereinafter:

1. Install 1 spacer on the M versions with flowrate below 800 l/h models
2. Remove it from the R version with flowrate equal or lower than 300 l/h
3. Install 2 spacers in case of M and R series with maximum flowrate higher than 800 l/h and 300 l/h respectively. These are the models with 20 mm stroke length.

NOTE: Always make the connection using the appropriate connector. Do not use or connect other inductive sensors to the proximity connection. Make all the connections only when the pump is at a standstill.



Figura 3 Proximity and Spacer

4 PRODUCT DESCRIPTION

1 OPERATING PRINCIPLE

The KIT PRO is a management and control system for OBL's Black Line metering pumps. The KIT PRO can adjust the flow rate, changing the number of revs of the pump's electric motor. The KIT PRO has different operating modes (cf. chapter 5) to manage the pump's flow rate.

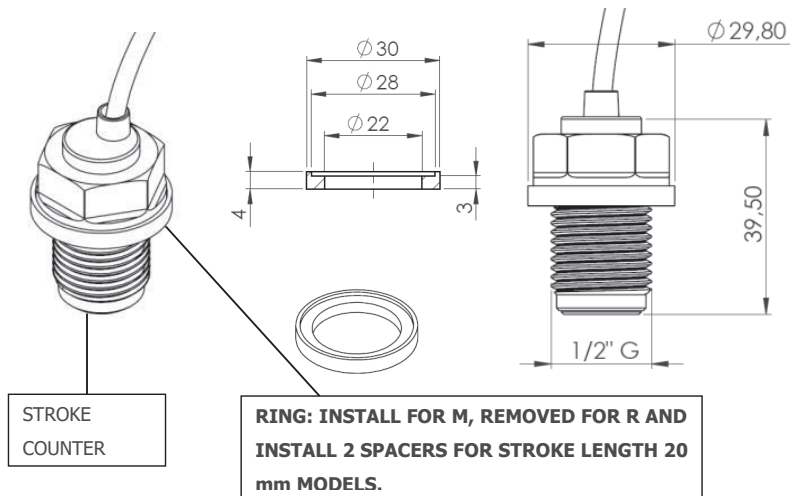
The KIT PRO can receive an input alarm signal from the instruments installed on the metering system, such as the level sensors.

The KIT PRO is provided with a display from where you can see the pump's operating status and enter the flow rate parameters. The different operating statuses of the pumps have different colours:

- Operating mode colour (green, blue, azure, lilac): correct operation
- Yellow: incorrect yet not dangerous operation
- Red: incorrect operation and pump lock

The PRO KIT does not adjust the stroke of the metering pump (cf. Use and maintenance manual of the Line Black pump, chap. 10.2).

The KIT PRO adjusts the ratio between maximum and minimum flow rate provided, as it adds the possibility to vary the number of revs of the electric motor and adjust the pump's stroke. This way, the turndown ratio can be of 500:1.

NOTE: The system does not automatically record every adjustment. Therefore, the flow rate and volume indicated by the software may differ from those actually provided, unless a calibration procedure is carried out (Table) with the new adjustment position.

2 MAIN COMPONENTS AND DIMENSIONS

As shown in the following figures, the KIT PRO consists of:

1. 1 enclosure containing the electronic control unit
2. 1 connection
3. 1 proximity sensor
4. 4 connectors with a 1-meter cable

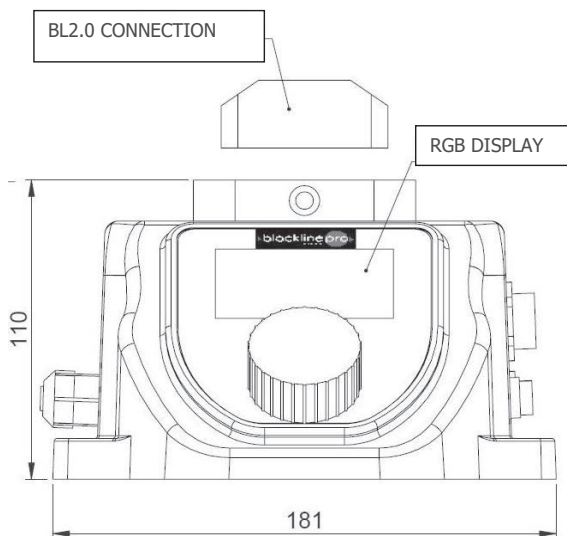

Figure 4 Front view

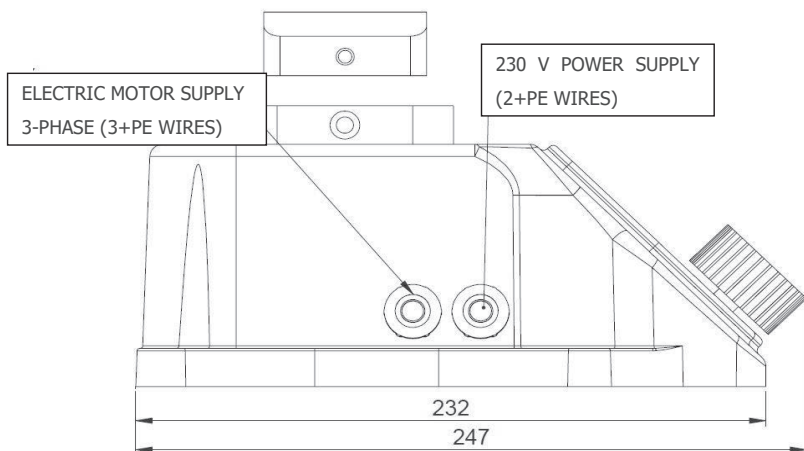

Figure 5 Side view of the supply lines

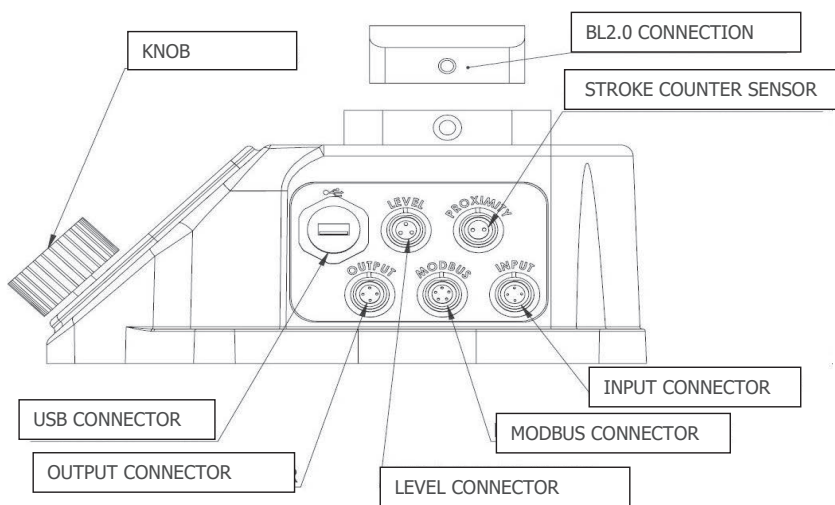

Figure 6 Side view of the supply lines

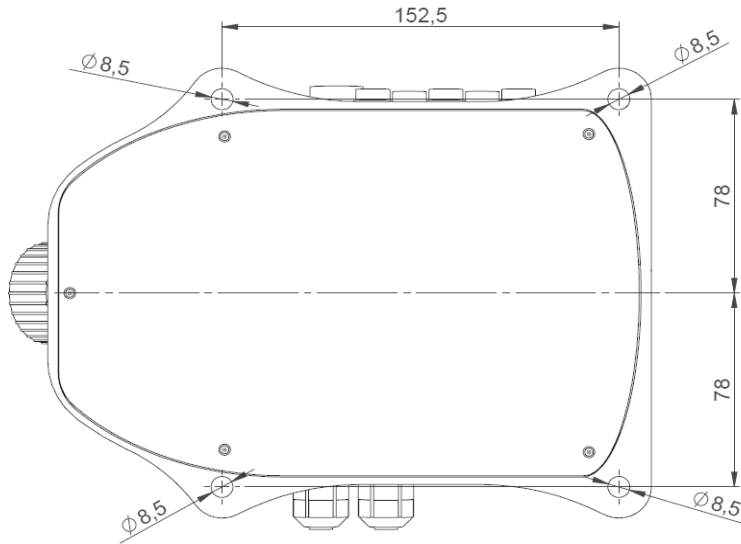

Figure 7 – Layout

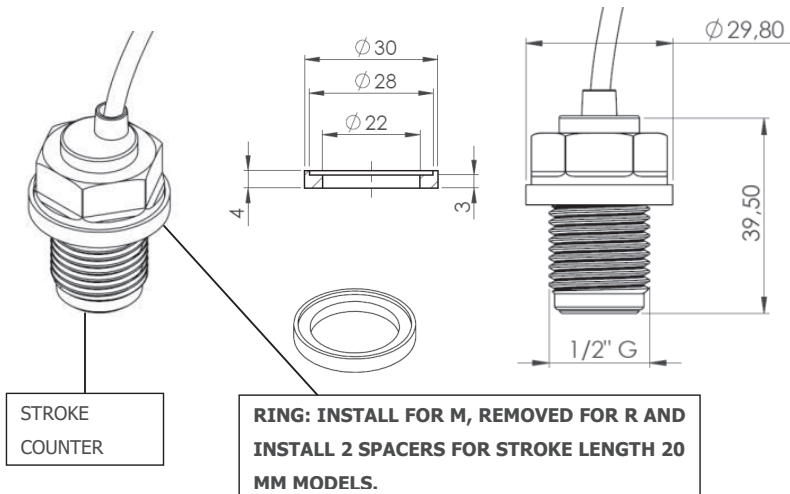

Figure 8 stroke counter sensor and ring

3 ENVIRONMENTAL CONDITIONS

As for installation, the environmental conditions must match the possible use conditions of OBL's metering pumps, which can be combined with the KIT PRO.

This product shall be used in Pollution degree 2 Environment.

4 TECHNICAL DATA

The KIT PRO is suitable for all OBL's metering pumps of the Black Line series with a standard motor (three-phase power supply 230/380V 50 Hz). Contact an OBL distributor in the event motors with different characteristics are installed.

Table 3- Technical data

		M	R	
Mechanical data	Max. flow rate (@ 1,5 bar)	1500 lt/hr	1050 lt/hr	
	Max pressure	12 bar	40 bar	
	Max. stroke frequency	155 strokes/min	114 strokes/min	
	Max. suction lift	1,5 m	1,5 m	
	Liquid temperature	-10°C÷+40°C	-10°÷+90°C	
	Max. weight	28 Kg	26 Kg	
	Accuracy	+/- 3%		
	Linearity	+/- 5%	+/- 3%	
	Repeatability	+/- 3%		
	Turndown ratio	500:1		
	Sound pressure	70 dbA		
	Materials (actuator, casing, motor)	Aluminum		
	Finishing (actuator, casing)	Electrophoretic deposition (EPD)		
	Electrical data	Max power consumption	1500W	
Max motor power		750W		
Max output current		3,3 A on 1,9 A off (0,2 s ON 50%) 3A (100%)		
Max input current		4.2 A		
Power Supply		110 V AC 230 V AC		
Frequency		50/60 Hz		
Operating temperature		-10/40 °C 14/113 °F		
Max inrush current		2,3A (110V) 5A (230V)		
Enclosure class (actuator only)		IP65		
Recommended fuse		6,3 x 32mm 8A		
USB	Type	USB 2.0 HOST		
Serial	MODBUS RTU	Half Duplex RS-485		
Input	4-20 mA	Max input Voltage /Control input	14 V DC	
		Impedance	120 Ω	
	0-10 V	Input Voltage /Control input passive	10 V DC	
		Impedance	15 kΩ	
	Pulse (PNP)	Voltage Range High Level	Min 19V DC - Max 29 V DC	
		Max resistance in pulse circuit	15 KΩ	
		Min pulse length	10ms	
Remote	Max load START/STOP digital input	28 V DC		
Level	Max load STOP digital input	28 V DC		

Output (HW 0.1)		Max load START digital input	28 V DC
	4-20 mA (passive)	Input Voltage /Control input	48 V DC
	Relays	Max load	24 V DC 3A
Output (HW0.2)	4-20 mA (active)	Max Out Voltage	21 V DC
		Max impedance	750 Ω
	Relays	Max load	24 V DC 3A

5 USE AND SOFTWARE

1 INTERFACE

The user interface consists of an encoder with a knob, which allows you to carry out two operations:

Table 1 Interface













ROTATION	Turn the knob to move a selector switch to the required item. Moreover, you can increase or decrease the value of a selected item.
CLICK	Press the knob to confirm a selected value or access different items of the menu.

2 ICONS

The icons used in the program and relative function are summarised in the following table:

Table 5 Icons

ICON	FUNCTION
	Main Menu

	Statistics
	Settings
	Previous page
	Off
	Start
	Stop
	Alarm
	Manual adjustment value
	Operating frequency
	Flow partialisation
	Reset
	Modbus

3 MENU

3.1 Home page



Figure 9 Home page

3.2 Operating modes

From the home page, click "operating modes" to select the operating mode you need. Each mode features an input screen (Figure 10) and an operating screen (Figure 11).

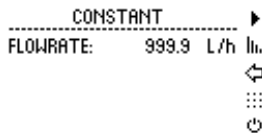

Figure 10 Input

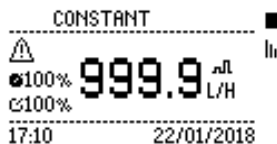

Figure 11 Operating screen

You can change the mode operating parameters or carry out operations by using the icons on the right side of every input screen:

1. Start: to start the set mode
2. Statistics (Figure 12): you can view:
 - a. The volume provided and the partial resettable activation time (by clicking on the reset icon)
 - b. The volume provided and the total non-resettable activation time





STATS		
PARTIAL VOL.	900.00 L	
PARTIAL LIFE	00d00h00m	
TOTAL VOL.	600.00 L	
TOTAL LIFE	00d00h00m	

Figure 12 Statistics

3. Back: to return to the previous menu
4. Settings: to open the setting menu
5. Off: to set the electronics in standby.

The operating modes available are shown in the following table:

Table 6 Operating modes

Modes	Input parameters	Description
Constant	FLOW RATE	The pump runs at a constant flow rate
Batch	VOLUME FLOW RATE START (MANUAL OR EXTERNAL)	The pump doses the volume of liquid at the set flow rate. Upon manual start, the process is repeated once and then it stops. Upon external start, the pump waits for the signal to start based on the set parameters and waits for a signal to repeat the process again.
PPM	PPM CONCENTRATION PULSE/L (L/PULSE) TIMEOUT	When the pump receives an external input signal sending pulses, it doses the liquid based on the liquid concentration value and ppm required at destination. The PULSE/L and L/PULSE parameters allow you to set the characteristics of the meter. The TIMEOUT parameter considers the maximum interval between two subsequent pulses.
Percentage	PERCENTAGE CONCENTRATION PULSE/L (L/PULSE) TIMEOUT	When the pump receives an external input signal sending pulses, it doses the liquid based on the concentration value of the liquid and the concentration required at destination (Percentage). The PULSE/L and

		L/PULSE parameters allow you to set the characteristics of the meter. The TIMEOUT parameter considers the maximum interval between two subsequent pulses.
MLQ	MLQ CONCENTRATION PULSE/L (L/PULSE) TIMEOUT	When the pump receives an external input signal sending pulses, it doses the liquid based on the concentration value of the liquid and millimetres per quintal (MLQ) required at destination. The PULSE/L and L/PULSE parameters allow you to set the characteristics of the meter. The TIMEOUT parameter considers the maximum interval between two subsequent pulses.
Pulse	MAXIMUM PULSE VALUE/M MINIMUM PULSE VALUE/M MAXIMUM FLOW RATE MINIMUM FLOW RATE TIMEOUT	When the pump receives a pulse input signal, it adjusts the flow rate based on the value of pulses per minute received between the maximum and minimum values. The TIMEOUT parameter considers the maximum interval between two subsequent pulses.
Analog mA	MA MAXIMUM VALUE (20 MA) MA MINIMUM VALUE (4 MA) MAXIMUM FLOW RATE MINIMUM FLOW RATE RANGE ALARM	The pump adjusts the flow rate based on an external analog signal and the maximum and minimum values set in the inputs.
Analog V	MAXIMUM V VALUE (10 V) MINIMUM V VALUE (0 V) MAXIMUM FLOW RATE MINIMUM FLOW RATE RANGE ALARM	The pump adjusts the flow rate based on an external analog signal and the maximum and minimum values set in the inputs.
Pause-work	FLOW RATE OPERATING PERIOD (MIN) PAUSE PERIOD (MIN)	The pump alternates pause periods with constant flow rate operation periods whose duration can be set.

Weekly	SET A PROGRAM: <ul style="list-style-type: none"> • PROGRAM No. • DURATION • START TIME • CONSTANT FLOW RATE • VOLUME • DAYS OF ACTIVITY 	This menu allows you to set the data of each program (max 13 programs). You can set the constant flow rate or volume of constant flow rate to be transferred, transfer duration, start time, and days of activity. We recommend not overlapping the programs.
	ACTIVE PROGRAMS	This menu shows the active programs and allows you to activate or deactivate them.

3.3 Partialisation

In the event that the required flow rate is 30% lower than the set flow rate during calibration, the pump starts the partialisation stage. This stage consists in:

1. Work stage, in which the pump runs at 30%
2. Pause stage

The duration of these two stages are calculated by the firmware so as to obtain the flow rate required.

The minimum flow rate provided is 1% the maximum flow rate. The pump fails to start if this value is not reached.

3.4 Settings

The setting menu is shown in Figure 13 and allows you to open all the functions described in Table

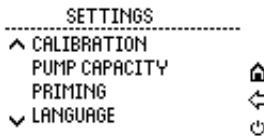

Figure 13 Settings

Table 7 Settings

Modes	Input parameters	Description
Calibration	TEST DURATION MOTOR POWER MAXIMUM MOTOR PHASE CURRENT MOTOR FREQUENCY	This mode allows you to test the pump's flow rate at the maximum frequency. The pump capacity screen appears at the end of the test.

		Moreover, you can set the test pressure (for test purposes only). Moreover, you can set the motor phase current (depending on the power) so that the system can block the pump once this current value is exceeded (table 8: motor short-circuit alarm). The system saves the date of the last test performed. NOTE: it is good practice to calibrate the pump every time process conditions change (pressure, manual adjustment value, etc.).
Pump capacity	MAXIMUM FLOW RATE TEST VOLUME ADJUSTMENT TEST PRESSURE DATE OF THE LAST TEST PERFORMED	In this screen, you can enter the flow rate or volume obtained during calibration. The maximum flow rate set will never be exceeded in the operating modes. The adjustment value is displayed in the operating screen.
Priming	PRIMING TIME	Set the priming time and click start to start the priming function. Press stop to stop the priming function.
Languages	IT EN ES FR NL RU DE TU	Select language
Password	USER ADMIN	Set the 4-digit password for each user (it blocks the parameter setting of the operating modes) or administrator (it blocks the access to settings).
DATE & CLOCK	DATE FORMAT (DD/MM/YY) TIME FORMAT (24/12 H) DATE TIME	You can choose how you want to display the date and time. These data are added to the statistics report.
UNIT OF MEASUREMENT	Flow Rate L/h and Gal/h.	Even the volume measurement units are updated accordingly.
PROXIMITY	Alarm activation with red display.	The proximity sensor (supplied) verifies the correct operation of the pump. The firmware stops the pump if the number of strokes is equal to 0

		with active pump. An error is recorded in the report. The error can be reset in the alarm log.
FIRMWARE INFO	INFO UPDATE FIRMARE EXPORT PARAMETERS IMPORT PARAMETERS EXPORT LOG DELETE LOG RESTORE TO FACTORY SETTINGS	This screen allows you to interface with the USB port, through which you can update the software, import and export parameters, export and delete reports, check the software version, and restore the default settings of the system. Export the report before updating the software so as not to erase the log file from the system.
MODBUS	MODBUS (YES/NO) BAUD RATE ADDRESS	This setting allows you to control the pump in Modbus.
ANALOG OUTPUT	OUTPUT	Possibility to activate the output of a proportional analog signal at the operating frequency.
RELAY	OUTPUT (OFF / START/STOP / ALARM) CONTACT (N.O. /N.C.)	This function allows you to use the relay with a N.O. or N.C. contact. The output signal indicates the pump's status (ON/OFF) or the presence of an alarm.
DISPLAY	MENU' LIGHT (ON/OFF) WORKING COLOUR (GREEN, PINK, BLUE, AZURE) CONTRAST (0-100%)	Display settings: backlight activation while browsing the menus, colour selection in operating modes, contrast.
LEVEL	STOP (YES/NO) CONTACT (N.O./N.C.) RED ALARM DISPLAY (YES/NO) START (YES/NO) CONTACT (N.O./N.C.)	Setting for starting or stopping the pump remotely (usually from a level sensor). You can also decide whether to activate the red display with the pump at a standstill. This setting uses the two pins on the level connector.
REMOTE START/STOP	START/STOP (YES/NO) CONTACT (N.O./N.C.)	Setting for starting or stopping the pump remotely. One single pin is used in this case. The pump starts when the contact is closed and

		blocks when the contact is open (or vice-versa, depending on the N.O. or N.C. contact).
OVERFLOW	ALARM (YES/NO) LIGHT ALARM (YES/NO) STOP OR WORK	In PPM, MLQ, and Percentage modes, you can activate an alarm (overflow) to block (STOP) or run (WORK) the pump if the flow rate calculation exceeds the flow rate set during the calibration stage.

3.5 Alarm log

The alarm log contains all the triggered alarms. Select the reset icon to reset an alarm.

ALARM REGISTER

PRO14 - 24/05/18 - 18:20



The alarms are summarised in Table .

Table 8 Alarms

ALARM CODE	ALARM TYPE	DESCRIPTION	CAUSE	VISUAL FEEDBACK (SCREEN)
TOU01	ELECTRONICS HARDWARE	TIMEOUT	Failed communication between two microcontrollers	FLASHING RED
CUR02	ELECTRONICS HARDWARE	OVER CURRENT	The motor current exceeds the limit	
TEM03	ELECTRONICS HARDWARE	OVER TEMPERATURE	The temperature exceeds the board limits.	
OVB04	ELECTRONICS HARDWARE	OVER BUS	Voltage exceeds the sheet limits	
INR05	ELECTRONICS HARDWARE	INRUSH	Inrush relays broken	
TRI06	MOTOR HARDWARE	TRIP	Motor short circuit	
PRO07	FUNCTIONAL	PROXIMITY	Motor or Pump block	
DFL08	FIRMWARE	DATA FLASH	Data setting error	FLASHING

EFL09	FIRMWARE	EXT FLASH	Log write error and FW update error	YELLOW
RTC10	ELECTRONICS HARDWARE	RTC	Clock error upon power-on (the clock is set to a non-admitted time). Flat battery.	
LOG11	FIRMWARE	LOG	Error in recording the file log	
LVL12	PROCESS	LEVEL	STOP input of the level sensor	FIXED RED
OVR13	PROCESS	OVERFLOW	Overflow alarm	FIXED RED OR FIXED YELLOW
RMT14	PROCESS	REMOTE STOP	Alarm resulting from remote stop	FIXED RED
AMA15	PROCESS	ANALOG mA	Input current beyond the range set in the analog mA mode.	FIXED RED
AVA16	PROCESS	ANALOG V	Input voltage beyond the range set in the analog V mode.	FIXED RED
UVG17 UVB18	ELECTRONICS HARDWARE		Power supply voltage too low.	

3.6 Analog Mode Calibration Procedure

The scope of the following procedure is to calibrate analog output and input mA signal to let the pump recognize 4 mA and 20 mA. When the measured value by PRO KIT is quite different from the input value (at least 0,3 mA difference), this procedure will help the accuracy of 4-20 mA signal.

Disable Analog Output

The first operation to be accomplished is to disable analog mA output:

- 1) Go to the menu "settings→Analog output"
- 2) Set the analog output to "NO" clicking on it



Figure 14

Loop installation

To the signal, the items required are:

Analog input:

- 1) Power loop (max 14 Vdc voltage in parallel on the pins)
- 2) Multimeter to measure 4-20 mA

Analog output:

- 3) Power loop (max 48 Vdc)
- 4) Multimeter to measure 4-20 mA

The loop must be connected to PRO according to the cables table described in the manual.

The multimeter shall be connected in series to close the loop and measure current. Please refer to multimeter manual for connection specifications.

Calibration

To calibrate the analog signal the necessary operations are the followings:

- 1) Power up the loop for analog input signal.
- 2) Go to the menu "setting→calibration"
- 3) Click the handwheel for 10 sec until will appear 3 new fields
 - a. Analog ma
 - b. Analog V
 - c. Analog Output
- 4) Click on analog input
- 5) A window with 2 values "4 mA" and "20 mA" will appear and a value on the bottom of the screen is proportional to the input current.
- 6) To calibrate 4 mA input signal:
 - a. Set current input at 4 mA.
 - b. Click on 4 mA (1100 as default)
 - c. Change the value
 - d. The value the bottom of the screen will change.
 - e. Change the value close to 4 mA to reach the value at the bottom of the screen.
- 7) To calibrate 20 mA input signal:

- a. Set current input to 20 mA.
 - b. Click on 20 mA (2300 as default)
 - c. Change the value
 - d. The value of current at the bottom of the screen will change.
 - e. Change the value close to 4 mA to reach the value at the bottom of the screen.
- 8) Click on the down arrow to memorize the calibrated value. (do not push the left arrow otherwise you have to calibrate 4 mA and 20 mA newly).
 - 9) Confirm the selection and go back to the previous menu.
 - 10) Click on analog output (if needed)



Figure 15

- 11) A window with 2 values "4 mA" and "20 mA" will appear.



Figure 16

- 12) To calibrate 4 mA signal:
 - a. click on 4 mA (1100 in the picture above)
 - b. change the value
 - c. the value of current measured by the multimeter shall change
 - d. Change the value until the multimeter will measure the desired 4 mA
- 13) To calibrate 20 mA signal:
 - a. click on 20 mA (2300 in the picture above)
 - b. change the value
 - c. the value of current measured by the multimeter shall change
 - d. Change the value until the multimeter will measure the desired 20 mA

- 14) Click on the down arrow to memorize the calibrated value. (do not push the left arrow otherwise you have to calibrate 4 mA and 20 mA newly).



Figure 17

- 15) Confirm the selection.

3.7 Modbus

Table 9 Modbus Specification

MODBUS SPECIFICATION	
Serial interface	RS 485 half duplex
Protocol	MODBUS-RTU
Baud rate	2400-4800-9600-19200-38400-57600-115200 bps
Start bit	1
Data lenght	8 bit
Parity bit	N. A.
Stop bit	1
Cyclic Redundancy Check (CRC)	CRC-16
ID slave address	1 to 247
Modbus paramerters registers	Da 40001 a 40058

Modbus commands registers	Da 41001 a 41016
Registers that can be read with 1 command	58
Registers that can be written with 1 command	58
Function Codes	03 (03 hex) – read holding register 16 (10 hex) – preset multiple holding register
Exclusion Codes	01 (01 hex) – illegal function 02 (02 hex) – illegal data value 03 (03 hex) – illegal data address 07 (07 hex) – NAK

The user can activate MODBUS functionality in settings menu.

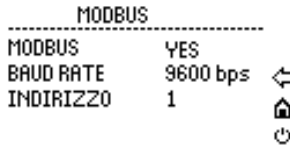

Figure 18 Modbus settings

In MODBUS window, the user can:

1. activate MODBUS (YES/NO)
2. set the baud rate (2400-4800-9600-19200-38400-57600-115200 bps).
3. set the slave device address

When MODBUS is active, the user can locally do the following operations:

1. When the motor is ON
 - a. To stop the pump (selecting STOP icon)
 - b. To display statistics
2. When the motor is OFF:
 - a. To navigate in the menu
 - b. It is not possible to start up the motor. The user has to turn off MODBUS mode to start up the motor.

When MODBUS is active, an icon will appear on the right corner of all windows of the firmware.

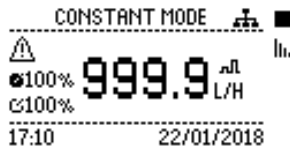

Figure 19 Modbus operating mode

COMMUNICATION EXAMPLE

Black Line PRO can communicate with a PLC using MODBUS interface.

Examples of communications are described hereinafter:

1. Read Holding Registers (Function Code 03)
 - a. Request:

This command is requesting the content of holding registers 40024 to 40025 from the slave device with address 01.

01 03 0017 0002 740F

- 01: Slave Address (01 hex)
- 03: Function Code (Read holding registers)
- 0017: The Data Address of the first register requested. (40024 - 40001 = 17 hex)
- 0002: The total number of registers requested. (read 2 registers 40024 to 40025)
- 740F: CRC (cyclic redundancy check) for error checking.

b. Response:

01 03 04 003C 003C 3A2E

- 01: Slave Address (01 hex)
- 03: Function Code (Read holding registers)
- 04: The number of data bytes to follow (2 registers x 2 bytes each = 4 bytes)
- 003C: The contents of register 40024
- 003C: The contents of register 40025
- 3A2E: The CRC (cyclic redundancy check).

2. Preset Multiple Registers (FC=16)

a. Request

This command is writing the contents of two holding registers 41003 and 41004 to the slave device with address 01.

01 10 03EA 0002 04 0000 0000 6968

- 01: The Slave Address (01 hex)
- 10: The Function Code (Preset Multiple Registers)
- 03EA: The Data Address of the first register. (41003 - 40001 = 03EA hex)
- 0002: The number of registers to write
- 04: The number of data bytes to follow (2 registers x 2 bytes each = 4 bytes)
- 0000: The value to write to register 41003
- 0000: The value to write to register 41004
- 6968: The CRC (cyclic redundancy check) for error checking.

b. Response

01 10 03EA 0002 6078

- 01: The Slave Address (01 hex)
- 10: The Function Code (Preset Multiple Registers)
- 03EA: The Data Address of the first register. (41003 - 40001 = 03EA hex)
- 0002: The number of registers written.
- 6078: The CRC (cyclic redundancy check) for error checking.

3. Read Holding Registers (FC=03) ERROR

a. Request

- This command is requesting the content of analog output holding registers 40100 (register out of range) from the slave device with address

- 01 03 9CA3 0001 5A78

b. Response

- 01 83 02 C0F1

01: The Slave Address (01 hex)

83: The Function Code (Preset Multiple Registers) with 1 to MSB

02: error code (illegal data address)

C0F1: The CRC (cyclic redundancy check) for error checking.

MODBUS LIST

The list of the registers and parameters that the user can write/read using Modbus is described in the following table:

Table 10 Modbus list

Nr. Reg.	PAR.	TYPE MOTOR OFF	TYPE MOTOR ON	BYTE	Min value	Max value	Default	U.M.	Description
40001	M_TIME_S	W/R	R	2	1	120	60	s	Calibration time - calibration settings
40002	M_FLOW	W/R	R	2	1	9999	600	(L/h or Gal/h)*10	Max flowrate - pump capacity settings
40003	M_PERC	W/R	R	2	1	100	50	%	Adjustment % - pump capacity settings
40004	M_L_PULSE	W/R	R	2	1	2000	200	L/p or p/L	L/pulse o pulse/L
40005		W/R	R	2	0	5	1		Languages Value 0= Italian Value 1=English Value 2=Spanish Value 3=Dutch Value 4=Russian Value 5=French
40006	M_FDATE	W/R	R	2	0	2	0		Date Format Value 0=DD/MM/YY Value 1=MM/DD/YY Value 2=YY/MM/DD
40007	M_24H	W/R	R	2	0	1	0		Time Format Value 0=24h Value 1=12 h
40008	M_UNIT_LH	W/R	R	2	0	1	0		Unit of measure Value 0=L/h Value 1=Gal/h
40009	M_YES_NO	W/R	R	2	0	1	1		Proximity red alarm Value 0=No Value 1=Yes

40010	M_YES_NO	R	R	2	0	1	0		MODBUS activation Value 0=No Value 1=Yes
40011	M_YES_NO	W/R	R	2	0	1	1		Analog output Value 0=No Value 1=Yes
40012	M_RELAY	W/R	R	2	0	1	1		Relay output activation Value 0=Off Value 1=START/STOP Value 2=Alarm
40013	M_COLOR	W/R	R	2	1	5	2		Display color Value 1=Display OFF Value 2=Green Value 3=Pink Value 4=Light blue Value 5=Blue
40014	M_PERC	W/R	R	2	0	100	50	%	Display contrast
40015	M_YES_NO	W/R	R	2	0	1	0		Red alarm display level and remote control Value 0=No Value 1=Yes
40016	M_YES_NO	W/R	R	2	0	1	0		Red alarm display overflow Value 0=No Value 1=Yes
40017	M_YES_NO	W/R	R	2	0	1	0		START/STOP remote control alarm Value 0=No Value 1=Yes
40018	M_CONTACT	W/R	R	2	0	1	0		Remote control contact Value 0=NO Value 1=NC
40019	M_YES_NO	W/R	R	2	0	1	0		Red alarm display overflow Value 0=No Value 1=Yes
40020	M_STOP_WORK	W/R	R	2	0	1	0		STOP/WORK overflow settings Value 0=STOP Value 1=WORK
40021	M_FLOW	W/R	R	2	1	9999	600	(L/h o Gal/h)*10	Flowrate constant mode
40022	M_VOLUME_INT	W/R	R	2	1	65535	1000	L o Gal	Volume batch mode
40023	M_FLOW	W/R	R	2	1	9999	600	(L/h o Gal/h)*10	Flowrate batch mode
40024	M_MINUTE	W/R	R	2	1	255	60	min	Working time pause-work mode
40025	M_MINUTE	W/R	R	2	1	255	60	min	Pausetime pause-work mode
40026	DIP_MIN	W/R	R	2	5	20	20	mA	High value current 4-20 mA analog mA
40027	DIP_MAX	W/R	R	2	4	20	4	mA	Low value current 4-20 mA analog

									mA
40028	DIP_MIN M_FLOW	W/R	R	2	1	9999	600	(L/h o Gal/h)*10	Max flowrate analog mA mode
40029	DIP_MAX M_FLOW	W/R	R	2	0	9999	0	(L/h o Gal/h)*10	Min flowrate analog mA mode
40030	DIP_MIN	W/R	R	2	1	10	10	V	High value voltage 0-10 V analog V mode
40031	DIP_MAX	W/R	R	2	0	10	0	V	Low value voltage 0-10 V analog V mode
40032	DIP_MIN M_FLOW	W/R	R	2	1	9999	600	(L/h o Gal/h)*10	Max flowrate analog V mode
40033	DIP_MAX M_FLOW	W/R	R	2	0	9999	0	(L/h o Gal/h)*10	Min flowrate analog V mode
40034	M_U16	W/R	R	2	1	65535	100	PPM	PPM desired in the tank PPM mode
40035	M_PERC	W/R	R	2	1	100	100	%	Concentration dosed fluid PPM mode
40036	M_PERC	W/R	R	2	1	100	100	%	Concentration in the tank percentage mode
40037	M_PERC	W/R	R	2	1	100	100	%	Concentration dosed fluid percentage mode
40038	M_U16	W/R	R	2	1	1000	100	MLQ	MLQ desired in the tank MLQ mode
40039	M_PERC	W/R	R	2	1	100	100	%	Concentration dosed fluid MLQ mode
40040	DIP_MIN M_P_M	W/R	R	2	2	1000	2	p/m	High value pules p/m pulse mode
40041	DIP_MAX M_P_M	W/R	R	2	1	1000	1	p/m	Low value pules p/m pulse mode
40042	DIP_MIN M_FLOW	W/R	R	2	1	9999	600	(L/h o Gal/h)*10	Max flowrate pulse mode
40043	DIP_MAX M_FLOW	W/R	R	2	0	9999	0	(L/h o Gal/h)*10	Min flowrate pulse mode
40044	M_PRESSURE	W/R	R	2	1	300	1	Bar	Calibration pressure – calibration window
40045	M_TYPE_START	W/R	R	2	0	1	0		Batch start Value 0=manual Value 1=external
40046	M_FLOW	W/R	R	2	1	9999	600	(L/h o Gal/h)*10	Flowrate pause work mode
40047	M_CONTACT	W/R	R	2	0	1	0		Contact output relay Value 0=NO Value 1=NC
40048	M_YES_NO	W/R	R	2	0	1	0		Level START contact activation Value 0=No Value 1=Yes
40049	M_YES_NO	W/R	R	2	0	1	0		Level STOP contact activation

									Value 0=No Value 1=Yes
40050	M_CONTACT	W/R	R	2	0	1	0		Level START contact Value 0=NO Value 1=NC
40051	M_CONTACT	W/R	R	2	0	1	0		Level STOP contact Value 0=NO Value 1=NC
40052	M_YES_NO	W/R	R	2	0	1	1		Menù light Value 0=No Value 1=Si
40053	M_BAUD	R	R	2	0	6	0		Baudrate MODBUS Value 0=2400 Value 1=4800 Value 2=Verde Value 3=Rosa Value 4=Azzurro Value 5=Blu
40054	M_TIME_S	W/R	R	2	1	120	120	s	Pulses time out in pulse mode, PPM mode, concentration mode e MLQ mode
40055	M_AMPERE	W/R	R	2	10	35	20		Motor current calibration window
40056	M_50_60Hz	W/R	R	2	0	1	0		50/60 Hz
40057	M_LP_PL	W/R	R	2	0	1	0		L/pulse pulse/L in PPM, MLQ e percentage modes
40058	M_U8	R	R	2	1	247	1		MODBUS ID
41001	OPERATING MODE	W/R	W/R	2	1	10	1	uint16	Operating modes Value 1=Constant Value 2=Batch Value 3=Pause-work Value 4=Weekly Value 5=Analog mA Value 6=Analog V Value 7=PPM Value 8=Percentage Value 9=MLQ Value 10=Pulse
41002	START-STOP	W/R	W/R	2	0	2	0	uint16	Starting motor Value 0=Stop Value 1=Start Value 2=Standby
41003	ALARMS	W/R	W/R	4	This value can be written only to 0			uint3	These registers inform the user about alarms according to the position of the bit BIT 0 "UVG17",//UNDER BUS GO BIT 1 "UVB18",//UNDER BUS GO BIT 2 "TOU01",//TIME OUT
41004									

										BIT 3 "CUR02",//OVER CURRENT BIT 4 "TEM03",//OVER TEMPERATURE BIT 5 "OV04",//OVER BUS BIT 6 "INR05",//INRUSH BIT 7 "TRIO6",//TRIP BIT 8 "PRO07",//PROXIMITY BIT 9 "DFLO8",//DATA FLASH BIT 10 "EFL09",//EXT FLASH BIT 11 "RTC10",//RTC BIT 12 "LOG11",//LOG BIT 13 "LVL12",//STOP LEVEL BIT 14 "OVR13",//OVERFLOW BIT 15 "RMT14",//REMOTE BIT 16 "AMA15",//ANALOG mA BIT 17 "AVA16",//ANALOG V
41005	PARTIAL LIFE	W/R	W/R	4	This value can be written only to 0			minutes	Durata della vita parziale della pompa. Scrivendo a zero il registro si resetta questo valore nel firmware.	
41006										
41007	PARTIAL VOLUME L	W/R	W/R	4	This value can be written only to 0			L*100	Volume parziale in litri erogato dalla pompa. Scrivendo a zero il registro si resetta questo valore nel firmware.	
41008										
41009	PARTIAL VOLUME Gal	W/R	W/R	4	This value can be written only to 0			Gal*100	Volume parziale in galloni erogato dalla pompa. Scrivendo a zero il registro si resetta questo valore nel firmware.	
41010										
41011	ADJUSTMENT	R	R	2				%	Adjustment	
41012	MOTOR	R	R	2				%	Frequency % of the motor	
41013	FLOW/VOL.	R	R	4	LSB			float	Flowrate or volume displayed on the screen	
41014					MSB					
41015	INFO	R	R	4	LSB			float	Sec, mA, V, flowrate, input, p/m displayed on the screen	
41016					MSB					

6 MAINTENANCE

1 ROUTINE MAINTENANCE

Routine maintenance includes operations that are carried out based on the operator's common sense, without following a strict schedule.



HAZARD

Do not carry out routine maintenance operations on mains-powered equipment.

Routine maintenance operations carried out by the user:

- Cleaning



Frequently clean the pump. Dirt and residues must not cover the adjustments or the interface screen.

2 TROUBLESHOOTING

To make a self-diagnosis of the product, see subchapter "Alarm log".

Contact the manufacturer if you detect defects and/or malfunctions that are not described in this manual.

7 ACCESSORIES AND SPARE PARTS

1 ASSISTANCE

Contact the manufacturer for any information relative to installation, use, and maintenance of the product.

For the sake of clarity, the client must always refer to this manual and the instructions listed.

2 SPARE PARTS



**ALWAYS USE ORIGINAL SPARE PARTS.
FOR ANY SPARE PART, CONTACT THE MANUFACTURER.**

The following spare parts are available for the KIT PRO:

Table 11 Spare parts

Spare part kit code	Description	KIT component code	Description
KME60	Connection cables (4 pieces)	KME60	Connection cables (4 pieces)
KPRA08	Proximity sensor	KPRA08	Proximity sensor
KKPRO	Spare part kit for routine maintenance	P20.2189	Pump connection
		KMV150	Knob
		P20.2193	Front label

We do not recommend using non-original spare parts. If you decide to use them, all the Warranty terms and conditions, if still valid, will be void and null and the Manufacturer will not be held responsible for any damage to people and/or property.

8 ADDITIONAL INSTRUCTIONS

1 DECOMMISSIONING AND DISASSEMBLY

It is the user's responsibility to comply with the procedures and regulations in the countries of operation, regarding disposing of waste resulting from maintenance (consumption material) or the demolition of equipment.

"Waste" is intended as any substance or object which the holder has decided to or is required to discard. Waste is classified according to the origin, in "urban waste" and "special waste" and, according to harmfulness, in "hazardous waste" and "non-hazardous waste".



Maintenance or demolition pump waste are classified as "special waste" only if properly cleaned. Otherwise, they are to be considered "HAZARDOUS special waste".



"Special waste" and "urban waste", and especially "hazardous" and "non-hazardous" waste, must never be mixed."

Briefly summarising:

- "special waste" must not be disposed of as "urban waste"
- this waste must be collected separately using public or private collection systems required by local laws (in an approved collection centre)
- due to its use, this equipment may contain hazardous substances. Improper disposal can have adverse effects on human health and the environment.
- administrative sanctions exist in the case of improper disposal of or abuse of waste



Disposal of substances into sewers or abandoning waste in the environment is strictly prohibited. Contact your local waste disposal service to receive adequate and accurate information regarding disposal.

oblblackline.com

OBL S.r.l.

Via Kennedy, 12
20090 Segrate (MI) - Italy
Tel. +39.02.269191
Fax +39.02.2133893
obl.info@idexcorp.com
oblpumps.it

