

Item	Description	Q'ty	Type	Material	Part No.	Code No.	
1	Front Case (+Case Plate) Unit	1		CFRETFE+Steel	SMF0163	1231245700	
2	Rear Case (+Liner Ring) Unit	1	CF•RF	CFRETFE+Ceramic	SMF0107	1210048510	
		1	KK	CFRETFE+SiC	SMF0108	1210048520	
3	Rear Casing	1		CFRETFE	SMF0109	1220319900	
4	Volute Spacer	1	F542•543•545-V	CFRETFE	SMF0110	1240885000	
		1	F543•545-T	CFRETFE	SMF0144	1240884900	
6	Plate	1		CFRETFE	SMF0111	1220320700	
7	Cap	1		CFRETFE	SMF0010	1240856300	
8	Drain Cap	1		CFRETFE	SMF0011	1240856500	
9	Impeller (with Mouth Ring) Unit	1	CF•RF	F542•543•545-V	CFRETFE+PTFE	SMF0113	1240884710
			F543•545-T	CFRETFE+PTFE	SMF0146	1240884610	
		1	KK	F542•543•545-V	CFRETFE+SiC	SMF0114	1240884720
			F543•545-T	CFRETFE+SiC	SMF0148	1240884620	
*10	Drive Magnet Unit <*See Note below>	1	<J2>	F542 [1,5kW]	FCD450+R-E Mag.	MX0310	1230987200
			<J3>	F543 [2,2kW]	FCD450+R-E Mag.	MX0323	1230987300
			<XJ5>	F545 [4,0kW]	FCD450+R-E Mag.	MXM0092	1220300200
11.1	Magnet Capsule+ Bearing Unit	1	CFV•CFE	F542	CFRETFE+Carbon	MX0453	1231022710
			RFV•RFE	CFRETFE+PTFE	MX0454	1231022720	
			KKV•KKE	CFRETFE+SiC	MX0455	1231022730	
		1	CFV•CFE	F543•545	CFRETFE+Carbon	MX0462	1231022810
			RFV•RFE	CFRETFE+PTFE	MX0463	1231022820	
			KKV•KKE	CFRETFE+SiC	MX0464	1231022830	
11.2	Lock Pin	2		CFRETFE	MX0489	1240765900	
13.1	Cap Bolt	6	M10x50	SUS304 equivalent	SMX0119	0150300254	
13.2	Cap Bolt	3	M10x16	SUS304 equivalent	SMX0120	0150300040	
13.3	Cap Bolt with W.	F542•543	4	M8x20	Steel	MX0219	0150900033
	Cap Bolt	F545	4	M10x16	SUS304 equivalent	SMX0120	0150300040
13.4	Cap Bolt	2	M10x90	SUS304 equivalent	SMX0121	0150300615	
14.1	Hex. Head Bolt	F542•543	4	M10x30	SUS304 equivalent	MDM0040	0150100182
		F545	4	M12x40	SUS304 equivalent	MDM0555	0150100208
14.2	Hex. Head Bolt	F542•543	4	M10x25	SUS304 equivalent	MDM0041	0150100181
		F545	4	M10x30	SUS304 equivalent	MDM0040	0150100182

*Note: "Drive Magnet Unit" (Item No. 10) is furnished with 2 x Setscrew (M8x10).

△Subject to change without prior notice! △Actual pump may differ from the exploded view!

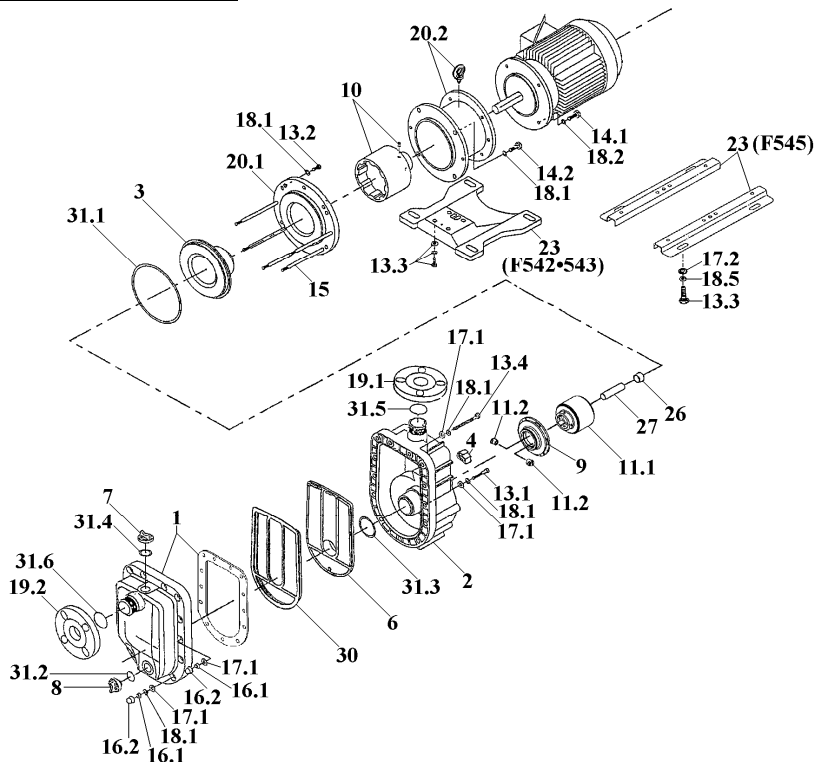

Item	Description	Q'ty	Type	Material	Part No.	Code No.	
15	Stud Bolt	5	M10x168	SUS304	SMX0122	1240859400	
16.1	Nut	13	M10	SUS304 equivalent	SMX0123	0153100031	
16.2	Cover Cap	13		PE	SMX0124	0159000003	
17.1	Plate Washer	21	M10	SUS304 equivalent	SMX0125	0153500028	
17.2	Plate Washer	F545	M10	SUS304 equivalent	SMX0139	0153500073	
18.1	Spring Washer	28	M10	SUS304 equivalent	MDM0030	0154100022	
18.2	Spring Washer	F542•543	M10	SUS304 equivalent	MDM0030	0154100022	
		F545	M12	SUS304 equivalent	MDM0029	0154100024	
18.5	Spring Washer	F545	M10	SUS304 equivalent	MDM0030	0154100022	
19.1	Discharge Flange	1	40mm	CFRETFE	MX0477	1230404400	
19.2	Suction Flange	1	50mm	CFRETFE	MX0483	1230253600	
20.1	Rear Casing Support	1		FCD450	SMF0140	1220317600	
20.2	Adapter	F542•543	1	1,5•2,2kW	FCD450	SMX0127	1210044500
	<*See Note below>	F545	1	4,0kW	FCD450	SMX0140	1210044600
23	Base	F542•543	1		GFRPP	SMX0073	1220303100
		F545	2		Steel	SMX0143	1231204000
26	Rear Thrust	1	CF•RF	Alumina Ceramic	SMX0107	1240858400	
		1	KK	SiC	SMX0108	1240858500	
27	Spindle	1	CF•RF	Alumina Ceramic	SMX0109	1240864000	
		1	KK	SiC	SMX0110	1240864100	
30	Gasket	V		FKM-A	SMX0111	1220310600	
		E		EPDM	SMX0112	1220310700	
31.1	O-Ring <R.Casing>	V		FKM-A	SMX0113	0325300491	
		E	G-180	EPDM	SMX0114	0325300492	
31.2	O-Ring <Drain>	V		FKM-A	MX0117	0325300203	
		E	G-25	EPDM	MX0205	0325300179	
31.3	O-Ring <R. Case>	V		FKM-A	SMX0115	0325300326	
		E	G-55	EPDM	SMX0116	0325300493	
31.4	O-Ring <Cap>	V		FKM-A	SMX0029	0325300053	
		E	G-30	EPDM	SMX0030	0325300087	
31.5	O-Ring <Outlet>	V		FKM-A	MX0130	0325500010	
		E	AS568-129	EPDM	MX0233	0325500014	
31.6	O-Ring <Inlet>	V		FKM-A	MX0181	0325500011	
		E	AS568-136	EPDM	MX0300	0325500015	

*Note: "Adapter" (Item No. 20.2) is furnished with 1 x Eyebolt (M10).

⚠ Subject to change without prior notice! ⚠ Actual pump may differ from the exploded view!